

# Lifting & Hoisting

## Chain Blocks

### 30t Heavy Weight Chain Block

With powerful lifting capacities and engineered to meet the toughest industrial applications, our durable 30t heavy weight chain block is built to handle the most demanding lifting operations, whilst ensuring worker safety and efficiency.

*Capacity:*  
30.0t

*Applications:*  
Construction, Heavy Engineering, Manufacturing, Mining, Offshore Exploration.

*Complies with:*  
AS/NZS1418

#### Product Features

- Factory tested to 1.5 x W.L.L.
- Super strength zinc plated alloy load chain.
- Lower hook complete with thrust race bearing.
- Fully machined lift wheel, supported by needle roller bearings.
- Weather protected automatic Weston brake with unique Twin Pawls.



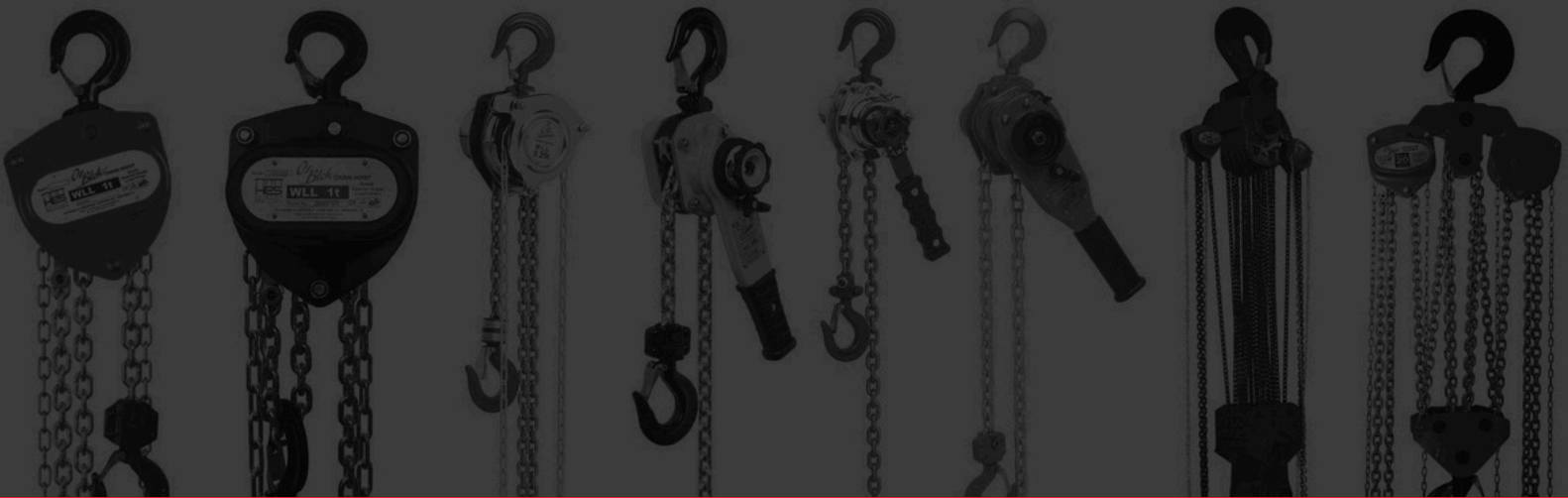

# Lifting & Hoisting

## Chain Blocks

### SPECIFICATIONS

PRODUCT CODE	WORKING LOAD LIMIT (W.L.L.)	STANDARD LIFT	FALLS OF CHAIN	HAND EFFORT TO LIFT W.L.L.	LOAD CHAIN Ø	NET WEIGHT
CBOZ300-3	30.0t	6m	12	40kg x 2	10mm	279.6kg

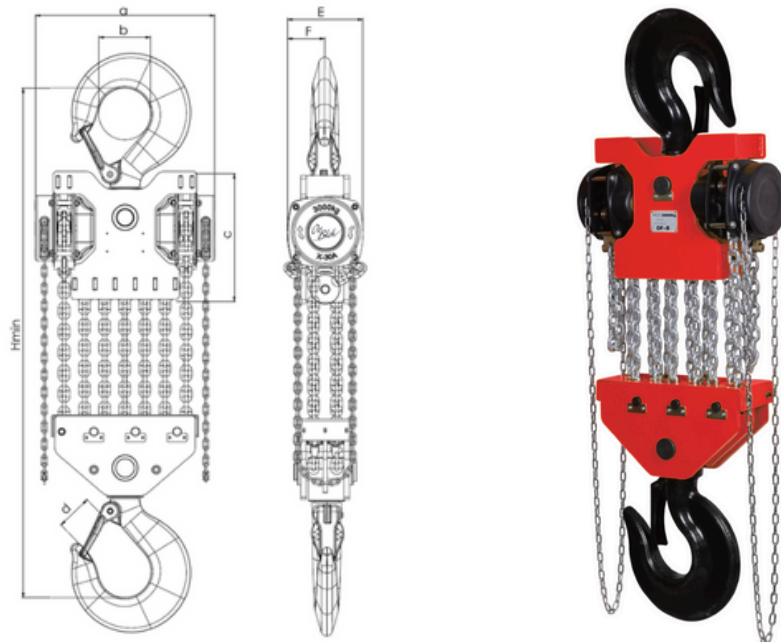

### DIMENSIONS

PRODUCT CODE	WORKING LOAD LIMIT (W.L.L.)	A	B	C	D	E	F	Hmin
CBOZ300-3	30.0t	533mm	150mm	105mm	373mm	220mm	109mm	1139mm