

Lifting & Hoisting

Girder Trolleys

Stainless Steel Geared Girder Trolley

Ideal for lifting applications in humid and acidic environments, this rugged lightweight industrial grade geared girder trolley is made from 304 grade stainless steel for optimal rust and corrosion resistance. Designed to facilitate the horizontal traverse of a hoist along a girder, and with built in side plates and trolley wheel guards, this trolley provides optimal user safety whilst meeting the most demanding lifting applications.

Capacity:
1.0t to 5.0t

Applications:
Food Industry, Manufacturing, Marine, Mining,
Pharmaceutical Production.

Complies with:
AS/NZS1418

Product Features

- Anti-derailment side plates.
- 304 grade stainless steel construction.
- Suitable for use with a manual or powered hoist.
- Independent hanger for attachment of chain blocks.
- Precision sealed machine ball bearing trolley wheels.



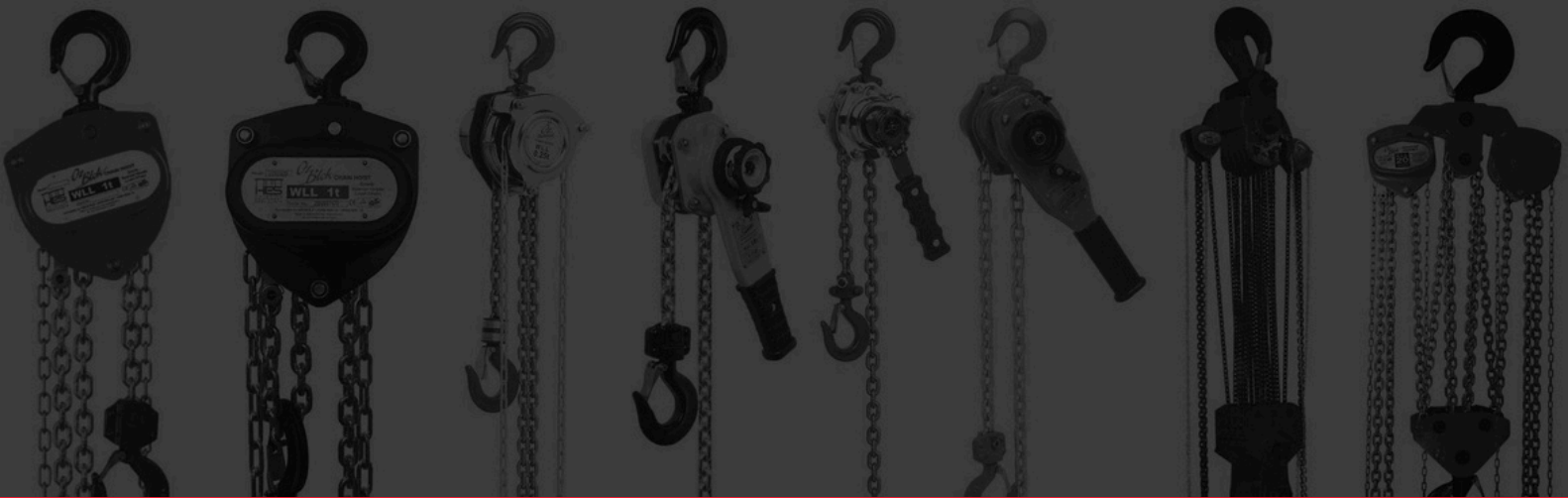

Lifting & Hoisting

Girder Trolleys

SPECIFICATIONS

PRODUCT CODE	WORKING LOAD LIMIT (W.L.L.)	ADJUSTABLE BEAM WIDTH	MIN. RADIUS CURVE	NET WEIGHT
GTOZSS010	1.0t	64mm – 210mm	1.0m	18kg
GTOZSS020	2.0t	88mm – 210mm	1.1m	27kg
GTOZSS030	3.0t	102mm – 210mm	1.3m	43kg
GTOZSS050	5.0t	114mm – 210mm	1.4m	60kg

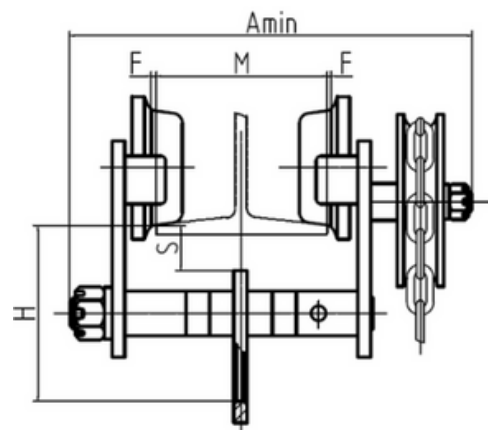
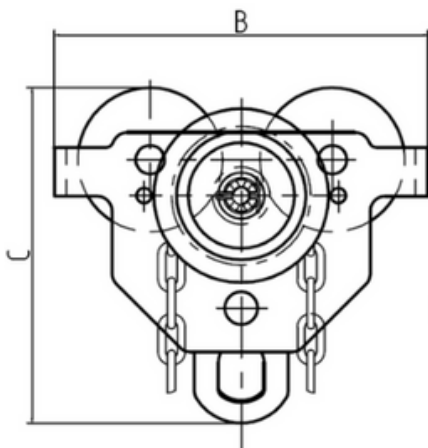

DIMENSIONS

PRODUCT CODE	WORKING LOAD LIMIT (W.L.L.)	A	B	C	H
GTOZSS010	1.0t	380mm	260mm	239mm	135mm
GTOZSS020	2.0t	390mm	300mm	286mm	161mm
GTOZSS030	3.0t	413mm	345mm	336mm	188mm
GTOZSS050	5.0t	430mm	395mm	393mm	220mm